

# *New Orleans*

*Exhibit A wide*

*Corrections:*

*Being Ready For Any Challenge*

*138th Congress of Correction*

*American Correctional Association*

*August 8-13, 2008*



# *138th Congress of Correction*



*YOU ARE CORDIALLY INVITED TO EXHIBIT AT ...*

*The American Correctional Association's  
138th Congress of Correction  
Morial Convention Center  
New Orleans, Louisiana  
August 8-13, 2008*

*The ACA 138th Congress of Correction has become the largest gathering of corrections personnel in the United States. Exhibitors have learned first hand that the decision makers and purchasers of products and services visit this show annually. Don't miss this opportunity to reach this exclusive group!*

*Booth space is now available! Generate invaluable business and goodwill for your company by making the ACA's 138th Congress of Correction part of your 2008 schedule. Sign up TODAY by completing the exhibit booth reservation form on page 10 and 11.*



# Meet the Decision Makers

## 138<sup>th</sup> Congress of Correction AUGUST 8-13, 2008 NEW ORLEANS, LOUISIANA

**F**or more than 100 years, corrections professionals from across the country and around the world have relied on ACA's Congress of Correction for information on the latest products, services and technologies that will impact their profession.

The ACA 138th Congress of Correction attracts the best in the field to learn, network and explore the future by walking through the Exhibit Hall. The ACA Exhibit Hall allows members and guests to see, touch and experience the products that make their jobs safer, more efficient and more productive. Wardens, superintendents, administrators, purchasing agents and other qualified and authorized buyers will be in New Orleans, Louisiana to see first hand your cutting-edge technologies and state-of-the-art products.

This is a great opportunity to meet face-to-face with more than 3,000 decision makers who have the need and budgets for your products, services and technologies.

### TOP OF THE PROFESSION – ACA MEMBERSHIP REACHES MORE THAN 20,000 CORRECTIONS PROFESSIONALS

35% TOP ADMINISTRATORS  
40% MIDDLE MANAGEMENT  
75% TOTAL MANAGEMENT  
25% LINE/ADMINISTRATIVE SUPPORT STAFF

***MORE THAN \$70 BILLION WAS SPENT BY LOCAL, STATE AND FEDERAL GOVERNMENTS FOR CORRECTIONS IN 2006.***



# What is ACA?

Founded in 1870 as the National Prison Association, the American Correctional Association (ACA) is the oldest and largest correctional association developed specially for practitioners in the corrections profession. ACA represents more than 20,000 active professional members. The membership, located in the United States, Canada and other nations, consists of individuals and organizations involved in all facets of corrections including adult and juvenile institutions, community corrections, juvenile justice, health care, probation and parole. ACA is the leader in the improvement of corrections and the professional development of experts in the field.



The Association provides its members with educational materials, publications, training courses, seminars, bi-annual conferences, accreditation services and a variety of other networking opportunities, not to mention *Corrections Today* magazine and discount programs. Working toward a unified voice in correctional policy, ACA has been actively involved in:

- Developing national correctional philosophy;
- Designing and implementing standards for correctional services and methods for measuring compliance; and
- Providing publications, training and technical assistance.

## ACA's Mission Statement

*The mission of the Association is to exert a positive influence on national correctional policy and to promote the professional development of individuals working in all aspects of the corrections field. Our primary purpose is to be of service to both the field and to our members.*

## Special Invitation to Treatment Providers



Launched in 2007 at the Winter Conference in Tampa, Fla., the **Healthcare Professional Interest Section (H-PIS)** of ACA brings together health care practitioners and providers with correctional leaders and security professionals to examine important health care and treatment issues relevant to the corrections field, and to improve communications and operations for all facets of corrections.

ACA is the only organization in the nation that is working with correctional treatment and security professionals toward common goals — quality training and open dialogue. **Many workshops, special events, social activities and meetings are planned for H-PIS members at the 138<sup>th</sup> Congress of Correction.**

Please join ACA in New Orleans and participate in this important program with local, state and federal corrections professionals, representing all aspects of the field, to help improve our services, protect the public, and prepare women and men for release back into society.

# Exhibit Information & Pricing

## EXHIBITOR INFORMATION

All booths are standard 10-feet- deep by 10-feet-wide, unless otherwise indicated on the floor plan. Electricity and water are available throughout the Morial Convention Center. Check Exhibitor Kit for details.

### PRICING FOR COMMERCIAL BUSINESSES

10' x 10' BOOTHS	\$2000 (Strategic Location) \$2400 (Corner Location)
10' X 20' BOOTHS	\$4000
20' X 20' BOOTHS	\$8600

### PRICING FOR NOT-FOR-PROFIT ORGANIZATIONS

To assist small organizations and associations, ACA will grant a 50% discount of the booth cost for those organizations who qualify.

- Classified as a nonprofit organization — 501(c)(3) or 501(c)(6) documentation
- Express interest to exhibit and need to reach corrections decision makers

#### BOOTH FEE INCLUDES:

- 10' x 10' booth space with draped 8' backwall and 3' siderails
- Company identification sign
- Two (2) complimentary full registrations for company personnel
- Four (4) complimentary floor passes limited to individuals directly employed as staff of your company (additional passes available for a fee of \$50 each)
- 24-hour security service
- Daily aisle maintenance
- Listing in the 138th Congress of Correction Program Book
- Admission to social events (except for E.R. Cass Banquet) available to full registrants only
- Access to all workshops, seminars and sessions available to full registrants only

### EXHIBIT DATES AND HOURS

#### EXHIBITOR MOVE-IN

- |                            |                  |
|----------------------------|------------------|
| • Saturday, August 9, 2008 | 10:00am - 4:00pm |
| • Sunday, August 10, 2008  | 8:00am - 1:00pm  |

#### SHOW HOURS\*

- |                            |                  |
|----------------------------|------------------|
| • Sunday, August 10, 2008  | 4:30pm - 6:30pm  |
| • Monday, August 11, 2008  | 10:00am - 4:00pm |
| • Tuesday, August 12, 2008 | 9:30am - 12:00pm |

*\*Hours are tentative and subject to change*

#### EXHIBITOR MOVE-OUT

- |                              |                   |
|------------------------------|-------------------|
| • Tuesday, August 12, 2008   | 1:00pm - 6:00pm** |
| • Wednesday, August 13, 2008 | 8:00am - 10:00am  |
- \*\*Exhibitors must wait for aisle carpet to be removed by decorator before move out can begin.**

### RESERVING EXHIBIT SPACE

The exposition will take place at the Morial Convention Center August 10-12, 2008. You may select your preferred booths using the exhibit hall floor plan. Complete and sign the booth reservation contract and send to the American Correctional Association via fax or mail with a 50% deposit for the total booth space. (the deposit is not refundable and nontransferable). Upon receipt of your contract and payment, ACA will send a letter acknowledging receipt. A copy of the booth reservation contract with booth space confirmed by ACA, will be returned to you upon booth assignment. Booth assignments will begin no later than March 17, 2008.

### CANCELLATIONS

Should it become necessary to cancel the reservation, the booth rental fee, less the nonrefundable deposit, will be refunded upon written request received on or before May 14, 2008. After May 14, 2008, no refunds will be made nor will previously paid monies be applied to any future ACA exhibits or other marketing areas. Exhibitors applying after the May 14, 2008 cut-off date must submit the full booth rental fee, none of which is refundable, with the application.

**NOTE:** *Exhibit booths are not transferable and cannot be shared, sold, rented or given gratis to another company by the original contracting company.*

### 138TH CONGRESS OF CORRECTION PROGRAM BOOK AND EXHIBIT GUIDE

**All exhibitors reserving booth space on or before May 14, 2008 will be given a complimentary description listing in the official 138th Congress of Correction Program Book and Exhibit Guide.**

# Why Should Your Company Exhibit?

## ACA 138TH CONGRESS OF CORRECTION:

- ✓ Largest gathering of corrections professionals
- ✓ Partner with organizations that bring decision makers to you
- ✓ Education and certification programs provide access to this valuable audience
- ✓ Reinforce your commitment to the corrections field

## EXHIBITING AT ACA IS THE PERFECT PLACE TO:

- ✓ Meet customers face-to-face
- ✓ Discover the tools professionals are using to do business
- ✓ Improve relationships with existing clientele
- ✓ Leave memorable impressions with new contacts
- ✓ Build strong business connections
- ✓ Network and make new contacts
- ✓ Display new products, technologies and services
- ✓ Discover nuances about your target audience/market
- ✓ Recruit new contacts in the field

## REACH YOUR TARGET MARKET:

- ✓ Federal, state, provincial and local corrections professionals
- ✓ Administrators, supervisors, wardens and other corrections department officials
- ✓ Juvenile corrections administrators, superintendents and other employees
- ✓ Sheriffs, jail administrators and other employees
- ✓ Community corrections professionals
- ✓ Information technology managers
- ✓ Members from local and foreign government agencies
- ✓ Health care and other treatment professionals
- ✓ Executives from other related organizations
- ✓ Students within the criminal justice curriculum
- ✓ Line personnel

## ROI...

- ✓ A strong presence at the show will ensure name recognition long after the event ends.
- ✓ Collateral materials are kept and purchase decisions are made at a later date.
- ✓ This branding opportunity has the ability to generate revenue for your company.

*Your potential for business growth is unlimited...*

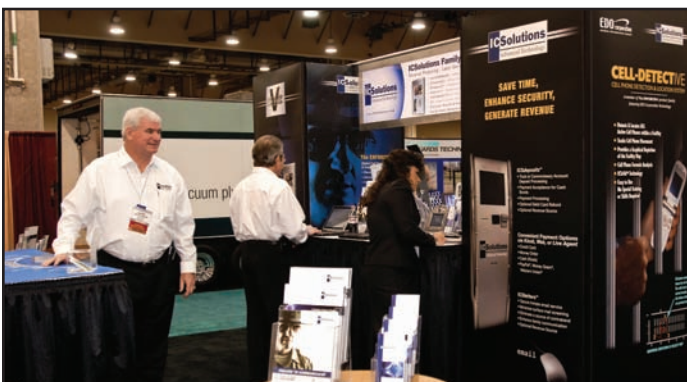

# MORIAL CONVENTION CENTER

## Exhibit Hall Floor Plan

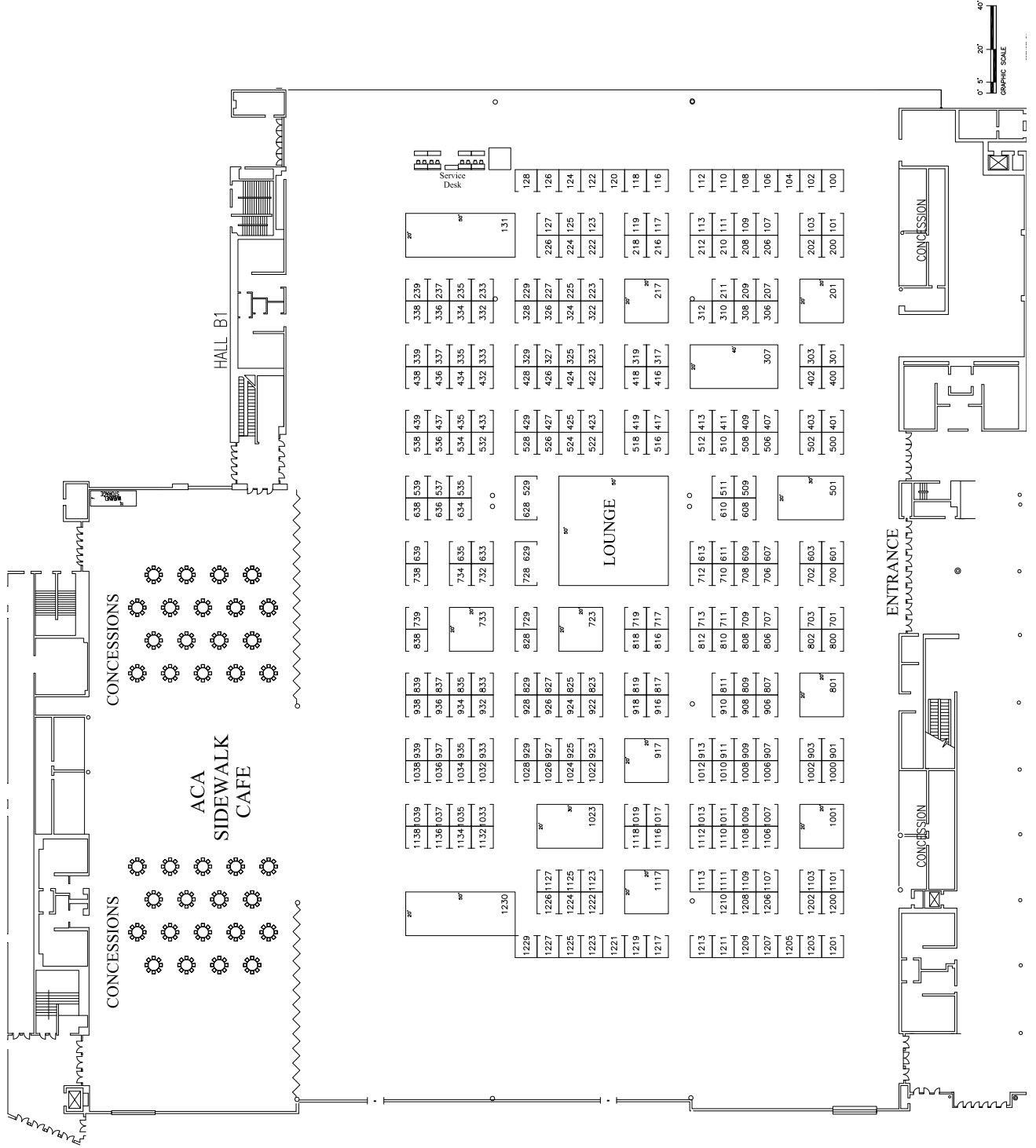

# Is your competition listed here? . . . .

## Most Recent ACA Exhibitors

Please note: New Companies are in Bold

5.11 Tactical  
Abbey Group Consultants  
Abbot Virology  
ABL Management, Inc.  
Acom Engineering Company  
Acall Security Products  
Active Parenting Publishers  
Actsoft Inc.  
Adams Electronics, Inc.  
Adams Metal Detectors  
Adelante Packaging & Assembly  
**Adelante Enterprises, Inc.**  
Advance  
Advanced Interactive Systems  
Advanced Tech Group Inc.  
Advanced Weapons Technology  
Adventist Prison Ministry Association  
AEDEC International, Inc.  
Afix Technologies  
AFLAC  
African American Expressions  
**AGM Telecom**  
AIDS in Prison Project  
Airius  
Airvac, Inc.  
Air-X  
Akron Brass Company  
Alanco/TSI PRISM, Inc.  
Alco Pro  
Alcoholics Anonymous  
**Aleier, Inc.**  
Alfa Scientific Designs, Inc.  
All Aboard Incorporated  
All State Distributors NE, Inc.  
Alliance Laundry Systems  
Allied Tube & Conduit Corporation  
ALS Technologies, Inc.  
Alternative Behavioral Service  
Alto U.S., Inc.  
Amatrol  
Amedica Biotech, Inc.  
American Bible Society  
American Bio Medica Corporation  
American Chariot Company  
American Commissary Supply  
American Dental Association  
American Foods Group  
American Institute of Architect  
American Jail Association  
Ameristar Fence Products  
Apex Industries  
Appriss, Inc.  
ARAMARK Correctional Services  
ARAMSCO  
Archibus  
Argon Security Technologies, Inc.  
Armed Forces Benefit Association  
Armor Correctional Health Services  
ASSA, Inc.  
Assessments.com  
Astra Zeneca Pharmaceuticals  
Astrophysics Incorporated  
ATD-AMERICAN CO.  
Athletic Style  
Atlantic Healthcare  
Atlas Business Solutions Incorporated  
Aurora Ministries  
Autco Distributing, Incorporated  
Avrio Group  
AWOIS AquaWing Ozone Injection Systems  
B & H Photo  
BAC  
The Backup Training Corporation  
Ballymore Medical Management  
Basic Ltd.  
**Bayco Products**  
Becker-Parkin Dental Supply  
Becton Dickinson and Company  
Bee Electronics Inc.  
Bell and Associates Construction

Bell Pro Police Products  
Bellevue University  
Benco Dental  
Berkley Square  
Best Lockers, LLC  
Best Plumbing Specialties  
BI Inc.  
BioMed Resource Inc.  
Bio-Pro Research  
Black Creek Integrated Systems  
Blonder Tongue Laboratories  
Bob Barker Company, Inc.  
Bobcat Company  
Boehringer Ingelheim Pharmaceuticals  
Bosch Security Systems  
Boswell Pharmacy Services  
Brijot Imaging Systems, Inc.  
R.R. Brink Locking Systems, Inc.  
Bristol-Myers Squibb Company  
Brother International Corp.  
Bruno-Abe's Place Kosher Meals  
BSN Sports  
Bureau of Justice Statistics  
Business Computer Applications (BCA)  
Caddell Construction Company Inc.  
California University of Pennsylvania  
Calmoseptine, Inc.  
CamLite Corporation  
CAMTECH  
Canine Associates International  
Canteen Correctional Services  
Capital Enterprise, Inc.  
Cardinal Health  
CareData Patient Tracking Systems  
Corporation  
Career Beginnings, Inc.  
**Casa Playa, LLC**  
Casco Manufacturing Solutions  
CBR Youth Connect  
CEEEO  
CEIA USA  
Cell Antenna Inc.  
Center for Disease Control  
Center for Sex Offender Management  
CE Shepherd Co., LP  
CETA Systems Inc.  
Chameleon Innovations  
The Change Companies  
Chase Doors  
Chestnut Ridge Foam, Inc.  
Chicago Metallic  
Chief Industries, Inc.  
Child Evangelism  
Cirqular, Inc.  
Clement Communications, Incorporated  
Client System  
Coastal Training Technologies  
Cobra Software Group  
Cobra Systems, Incorporated  
Colgate-Palmolive Company  
Colorado Correctional Industries  
Colorid  
Columbia Southern University  
Combined Public Communications  
COMM USA  
Command Concepts  
Community Education Centers  
Compass Knowledge Group  
Composite Armor Services-Lion Apparel  
Composite Technologies Corp.  
Conflict Resolution Services  
CONMED, Inc  
**Complex, LLC**  
Continued Learning  
Contract Pharmacy Services, Incorporated  
Control Screening LLC  
Conversant Technologies, Inc  
Conwood Sales Kodiak-Grizzly  
Cook's Correctional Kitchen Equipment  
Core Systems (NI) LTD  
Cornell Companies  
Correct Care

Correct Rx Pharmacy Services  
CorrectCare, Incorporated  
**Correctional Advisor's Group**  
Correctional Cable TV  
Correctional Communications,  
Correctional Counseling, Incorporated  
Correctional Education Association  
Correctional Healthcare Management  
Correctional Medical Services  
Correctional News  
Correctional Peace Officers Foundation  
Corrections Corporation of America  
Costa International  
Cover Your Assets LLC  
CPI Guardian  
CPS Human Resource Services  
Craftmaster Hardware  
Criminal Justice Media, Incorporated  
Cross Match Technologies Incorporated  
Crowley Co., Incorporated  
C-Tech Associates  
Dan Burns Associates, Inc.  
Darby Group  
DataStrip  
Dave Ramsey's Financial Peace  
DCCCA, Inc.  
Deister Electronics USA, Incorporated  
Dental EZ Group  
Department of Homeland Security  
Derby Industries  
DeSantis Holster & Leather Goods  
Design Specialties, Incorporated  
De-Tac International  
Defekion Security Systems  
Detex Corporation  
Diamond Pharmacy Services  
DIANAssociates  
Digital Datacatch/E-Quip  
DLR Group  
Dlubak Glass  
Domes International  
Donovan Industries  
**Drainable Direct**  
Dupont Advanced Fiber Systems  
Duro-Last Roofing, Incorporated  
Durrant Justice  
Dykes Restaurant Supply Co.  
Early Detect Incorporated  
Eastern Kentucky University  
Easter-Owens  
**Eclectic Products, Inc.**  
Ecolab, Incorporated  
EcoSMART Technologies  
Elbeco Incorporated  
Electronic Message Solution  
Elmo Tech, Ltd.  
EMBARQ  
Emerald City Software  
Emerald Companies  
**Emerald Systems, Inc.**  
Encartele  
Endorphin Corporation  
Envi International, Incorporated  
Environmental Interiors  
Envirox  
Envision  
EPIC Metals Corporation  
Epiphany Ministries  
ESI Companies, Incorporated  
ETS  
Excel Dryer  
Excelsior College  
Express Diagnostics International  
Fablock Mills  
The Facility Group  
Falcon GPS  
Family-Based Strategies  
Faronics Corporation  
Fast Forward By Scientific Learning  
Federal Prison Industries  
Ferguson Safety Products  
Fibrebond Corporation

First Choice Armor  
First DeFence II, Incorporated  
First Transit  
Flaghouse  
Florida Department of Corrections  
**FNH USA, LLC**  
Food Express Direct  
Forensic Laboratories  
Foxtail Foods  
**Free Linc**  
Futron, Inc  
G.R.E.A.T. Program  
G4S/Justice Services  
Gallagher Security Management  
Gateway Foundation, Incorporated  
GDI LLC  
GE Security  
**GE Security-Homeland Protection**  
General Marine Leasing, Incorporated  
The GEO Group, Incorporated  
Geovox Security, Inc  
Gibson Tech Ed Incorporated  
Gilead Sciences, Incorporated  
GlaxoSmithKline Pharmaceuticals  
Gleeds  
Global Diagnostic Services, Incorporated  
Global Security Glazing  
**Gordon Corrections**  
Grace & Hebert Architects Incorporated  
Grainger, Incorporated  
Grice Engineering, Incorporated  
Gryphyn Works  
GTL  
Guardian Solutions  
Habitat for Humanity International  
Hackett Security  
Handel Information Technologies  
Hardigg Cases  
Harding Instruments Co. Ltd.  
Hazelden Publishing & Educational Services  
HDR Architecture, Incorporated  
Health Professionals, LTD  
**Healthcare Providers Direct**  
Heery International  
Hellmuth, Obata & Kassabaum  
**Hillside Candy**  
Hillyard International  
Horizon Communities in Prison  
Hospital Equipment  
Hugonet  
Humane Restraint Company, Incorporated  
Hythiam, Incorporated  
IC Corporation  
iCard Forensics  
I.D. Tel Manufacturing and Supply  
Id Software, Incorporated  
Imperial Fastener Co. Incorporated  
Inmate Calling Solutions  
Innovacon, Inc  
Innovative Data Solutions  
In-Sink-Erator  
Instant Technologies  
Integrated Security Systems Incorporated  
Intellitech Corporation  
Interstate All Battery Center  
InTime Solutions, Incorporated  
The Invisible Armor  
Iowa Prison Industries  
ISECUREtrac Corporation  
ISI Detention Contracting  
**ITT Corporation**  
J.E. Dunn Construction Company  
JA Sexauer, Incorporated  
Jack Links  
Jacobs  
Janssen LP  
JAX, LTD  
JD Nelson and Associates LLC Safe4Hours  
Jefferson Audio Video Systems  
Jeron Electronic Systems, Incorporated  
Johnson Controls, Incorporated  
Johnson Diversely

# ..... Shouldn't you be????

JPay, Inc.  
**JPS Health Network**  
**Juice Pac, Inc.**  
Just Care, Incorporated  
Justice Packaging Corporation  
JWC Environmental  
Kaivac, Inc.  
Kane Detention  
Kaplan University  
Keefe Group  
Keith & Keith Corrections  
Kenall Lighting  
Key Systems, Incorporated  
Keytrak, Incorporated  
KuFBag  
Kurz  
Language Services Associates  
Laser Shot, Incorporated  
Leather Factory  
Legacy Inmate Communications Services  
Legal Research  
**Legendcare Pharmacy**  
Leightronix, Inc.  
Leslee Scott, Incorporated  
LexisNexis  
Lifesign  
LoneStar Field Products  
Loops Flexbrush, L.L.C.  
M T J American  
Machinist Union  
Magal-Senstar  
Magazine Subscription Svc. Agency  
Management & Training Corp.  
Manufacturing Software Solutions  
MAO Westwood Pharmacy, Incorporated  
Marathon Engineering Corp.  
Market Share, LLC  
**Mark's Plumbing Parts and Maintenance Supply**  
**Mar-Vel International**  
Mary Beth Inc  
Masterfoods USA  
MAXIMUS  
Maxor Correctional Pharmacy Services  
**McCaan Associates**  
MCI Telecommunications, Incorporated  
**MEDCOM Correctional Services, Inc.**  
Medical Doctor Associates, Incorporated  
Medical Partners of America  
Medical Staffing Network  
Medtox Diagnostics  
Metcraft Industries, Incorporated  
Metropolitan Interpreters & Translators  
MHM Correctional Services, Incorporated  
Michigan State Industries  
Micro Works  
MicroCentric Corp  
**Microflex Corporation**  
Mid America Coach, Inc.  
Mid America Health  
Mid-States Services, Incorporated  
Midwest Detention Systems, LLC  
**Mike Barber Ministries**  
Military Service Company  
Missouri Vocational Enterprises  
Mitsubishi Digital Electronic  
**Mobil Medical Int'l Corp.**  
ModuForm, Incorporated  
Monarch Coin & Security  
Montgomery Technology, Incorporated  
Morlite Systems, Incorporated  
Morse Watchmans, Incorporated  
Moseley Architects  
Motor Coach Industries  
Motorola, Incorporated  
Mountain High Coffee  
MPRI  
MSA  
MSC Industrial Supply Co  
MSDSonline  
Multimedia Telesys, Incorporated  
Mustang Company  
Myers Enterprises Incorporated  
Naphcare, Incorporated  
Narcotics Anonymous World Services

National Assoc. of Drug Court  
National Center for Construction  
National Fatherhood Initiative  
National Greyhound Foundation  
National Institute of Correction  
National Law Enforcement & Corrections Technology Center  
National Sheriff's Association  
National Correctional Industries  
National Institute on Drug Abuse  
National Law Enforcement Officer Memorial Fund  
Netspend  
New Directions  
New Heights, Incorporated  
New World Systems Corporation  
NextGen Healthcare Information Systems  
**Nexteq, LLC**  
NLECTC  
NLM-Institutional Linen Management  
Noresco  
Norix Group, Incorporated  
Norment Security Group  
North America Specialty Glass  
Northland Security Products  
Nurse Rosie Products  
O.D. Taragin & Brothers  
Oak Security  
Oakley, Incorporated  
Office Depot  
Office of Justice Programs  
Ohio University  
Oldcastle Precast Modular Group  
Olde Master Originals  
Oliver Products Co-Packaging  
Omnilink Systems  
**Omni View Innovations**  
Omron Electronics, Incorporated  
One Touch Systems  
Orbis Partners  
Original S.W.A.T. Footwear  
P.K. Food  
Paca Body Armor  
Pacific Concepts, Incorporated  
Panasonic Video Imaging System  
Pay Tel Communications, Incorporated  
PAYKEY™ USA Incorporated  
PDSI — TeleStaff  
Peak Cookquick Commissary Products  
Penn Emblem  
Penn State University  
Perfection Uniforms  
Pevac America  
Pfizer, Incorporated  
Phalanx Corporation  
Pictometry International Corp.  
Pitney Bowes  
**Planmeca, Inc.**  
Plastocon, Incorporated  
Point Blank Body Armor, Incorporated  
Polaroid ID Systems, Incorporated  
PortionPac Chemical Corporation  
Portland Hardware Co., Incorporated  
Portland Security Hardware Co.  
Positron Public Safety Systems  
Prelude Phone Products  
Price Industries  
Prime Coat Corporation  
Prime Health Services  
Prison Expression Cards LLC  
Prison Fellowship Ministries  
Prison Health Services  
Private Corrections Inst.  
Probatum Technologies, Incorporated  
Professional Claim Managers  
Proffitt's Machining, Incorporated  
Protech Corrections  
ProTech Monitoring, Incorporated  
Proteus on-Demand  
Public Communications Services  
Public Consulting Group  
PureTech Systems  
QQuest Corporation  
**Radiophone Engineering**  
Raoul Wallenberg Organization

Rapiscan Security Products, Incorporated  
Ray Bell Construction Company  
RB Tec, Incorporated  
**Read Naturally, Inc.**  
Redwood Toxicology Laboratory  
Reelizations Media  
Regent Medical  
Remington Technologies  
Research Electronics International  
The Restex Company, Inc.  
Restraint Systems Technologies  
Reverse 911  
Rip-N-Ready  
Riverdale Corporation  
Robinson Textiles  
Roche Laboratories Incorporated  
Rock River Arms, Incorporated  
**Rogers-Wallace Sales Group**  
Rose Report  
Rolando Weirich, Incorporated  
Rolonics Manufacturing, Incorporated  
RR Brink Locking Systems  
Safeguards Technology, Incorporated  
Sagem Morpho, Inc.  
The Salvation Army  
Sanitary Solutions  
Satellite Tracking of People LLC  
Scientific Learning Corporation  
Scott Health & Safety  
Screened Images Multimedia  
Secure Alert  
Secure Pharmacy Plus  
SecurePlex Systems  
Securitas, Incorporated  
Security Cameras Direct  
SECURUS Technologies  
Seder Foods Corporation  
Senstar-Stellar, Incorporated  
Sentry Security Fasteners  
Sequel Youth Services  
Sequest Technologies  
ShawnTech Communications, Incorporated  
Shield Defense  
Shoe Corp of Birmingham  
Shoe4Work  
Siemens Building Technologies  
SIGARMS, Incorporated  
Simple Green  
SMART Recovery  
Smith & Wesson  
Smiths Aerospace  
Smiths Detection  
Smooth On Incorporated  
SMRT Architecture Eng. Planning  
Social Security Administration  
SoftSheen/Carson, Incorporated  
Solo Slide  
Somnia Incorporated  
Sony/Continental Film  
South Western Communications  
Southern Folger Detention Equipment  
Southern New Hampshire University  
**Southern Sheriffs Supply**  
Southwest Microwave, Incorporated  
Spacesaver Corporation  
Special Made Goods & Services  
Specific Bags  
SpecPoint, Incorporated  
Speed Queen  
Spillman Technologies, Incorporated  
Sqwincher  
State Industrial Products  
Stinger Systems, Incorporated  
Stromberg  
Sturm Ruger & Co, Incorporated  
STV Architects  
Sundial Creations  
**Supplemental Health Care**  
Support 2020  
Survival Skills Ed. & Dev. (SSED)  
Swintec  
Symbol Arts, Incorporated  
Syscon Justice Systems, Ltd.  
T3 Motion, Inc.  
**Tactical Gear Now, Inc./AFMO.Com**

Tandy Leather Factory  
Taser International, Incorporated  
**TBN Second Chance**  
Teachers School Supply Incorporated  
Teijin Twaron USA, Incorporated  
Tele Staff by PDSI  
TELESTEPS Inc  
Texas Correctional Industries  
**Texas Tempered Glass, Inc.**  
The Force by Horace Mall  
The G-S Company  
The National MRSA Project  
This End Up Furniture Company  
Thomson-West  
Three Squares Greetings  
Tibotec Therapeutics  
Tiger Correctional Services  
TimeKeeping Systems, Incorporated  
Tindall Corporation  
**Toner Cable Equipment, Inc.**  
Touchpay Holdings LP  
Transactions Network Services  
Treanor Architect  
Truitt Bros. Incorporated  
Trussbilt  
TruTouch Technologies, Inc.  
Turner Construction Company  
TurnKey  
Tymetal Corp.  
TyaTech  
U.S. Chemical Storage  
U.S. Dept. of Justice - Civil Rights  
U.S. Medical Group, Incorporated  
U.S. Risk Advisors, Incorporated  
U.S. Risk Underwriters, Incorporated  
U.S. Smokeless Tobacco Brands  
UNICOR  
**Union Springs Pharmaceutical**  
Union Supply Company, Incorporated  
University of Findlay  
University of Louisville  
University of Maryland  
University of Northern Florida  
University of Phoenix On-Line  
USIS  
UTMB Correctional Managed Care  
Valiant Equipment Company  
**Value-Added Communications, Inc.**  
Verint Systems  
Verizon Business  
Verizon Wireless  
Versus Law  
VFA  
View Systems, Incorporated  
Vinyl Product  
Volunteers of America  
Voxtec International  
VPSI Incorporated  
VUGate  
Wallace International, Incorporated  
Wampole Laboratory  
Weldex Corporation  
**West Texas Lighthouse for the Blind**  
Western Union Payment Services  
Wexford Health Sources, Incorporated  
Wheatland Tube Company  
White Conveyors, Incorporated  
Willoughby Industries, Incorporated  
WinTron Technologies  
World Advertising of Tampa, Incorporated  
Woven Electronics  
Xtralis  
XWave  
Youth Advocate Programs  
Youth Build USA  
Youth Services International  
Z Medica  
Zee Medical  
Zenon  
Ziamatic Corporation  
Zimek Technologies, LLC

# American Correctional Association

## 138<sup>th</sup> Congress of Correction Booth Reservation Contract

### New Orleans, Louisiana • Aug. 8-13, 2008

**WE WISH TO RESERVE** \_\_\_\_\_ **10' X 10' BOOTH(S)**  
(Quantity)

**Please list your 10 selections in order of preference:**

1st choice \_\_\_\_\_ 3rd choice \_\_\_\_\_ 5th choice \_\_\_\_\_ 7th choice \_\_\_\_\_ 9th choice \_\_\_\_\_  
 2nd choice \_\_\_\_\_ 4th choice \_\_\_\_\_ 6th choice \_\_\_\_\_ 8th choice \_\_\_\_\_ 10th choice \_\_\_\_\_

**Company Name** \_\_\_\_\_  
(Name of organization as you wish it to appear in the 138<sup>th</sup> Congress of Correction Program Book and on exhibitor identification sign. Limited to 26 characters.)

\_\_\_\_\_  
(Street Address) (City) (State) (Zip)

\_\_\_\_\_  
(E-mail address) (Telephone) (Fax)

**Name of contact person/title to appear in the 2008 Winter Conference Program Book** \_\_\_\_\_

**Company Description** \_\_\_\_\_  
(Print 25 word description as you wish it to appear in the 138<sup>th</sup> Congress of Correction Program Book or attached separate sheet.)

Exhibitors we would prefer to be near \_\_\_\_\_  
(Company Name) (City) (State)

Exhibitors we would prefer **NOT** to be near\*\* \_\_\_\_\_  
(Company Name) (City) (State)

\*\* (Please indicate on a separate sheet of paper any other companies you would prefer not to be near. **ACA CANNOT GUARANTEE** your company will not be placed adjacent to a competitive firm but will try to accommodate your requests.)

We agree to rent the above indicated exhibit booth(s) subject to the American Correctional Association's exhibit regulations, which include all requirements set forth on this contract. **Enclosed is our nonrefundable and nontransferable deposit.** It is understood that space is being contracted on a prime-location basis and the amount of the booth rental fee balance will be dependent upon the location of the assigned booth(s) in the Exhibit Hall. Exhibitors assigned booths other than those requested will be deemed to have accepted those booths **unless a written request for change of location is received by ACA within 10 days of ACA's dated confirmation of booth assignment.** The booth rental fee, less the nonrefundable deposit, is payable upon receipt of invoice. If written cancellation requests are received by ACA on or before **May 14, 2008**, the exhibitor will receive a refund of the booth rental fee less the nonrefundable deposit. After **May 14, 2008**, no refunds of any amount will be made. Exhibitors applying after **May 14, 2008**, must submit the full booth rental fee, none of which is refundable, with their applications. **Companies cannot be listed in the 138<sup>th</sup> Congress of Correction Program Book unless the balance is paid in full.** Exhibit booths are NOT transferable and cannot be sold, subleased or assigned to another company by the original contracting company. **I hereby represent that I am authorized to submit this Booth Reservation Contract on behalf of my company, that I have read, understand and agree on behalf of my company to be bound by the terms of this contract and the accompanying brochure, that the information provided herein is true, and that I understand that this contract is complete only when accepted by ACA.**

Print Name: \_\_\_\_\_

Authorized Signature: \_\_\_\_\_ Date: \_\_\_\_\_

**AMERICAN CORRECTIONAL ASSOCIATION**  
 Attn: Exhibits  
 206 N. Washington, St., Suite 200 • Alexandria, VA 22314  
 1-800-222-5646, ext. 0022 • Fax: 703-224-0040  
 E-mail: sales@aca.org • www.aca.org  
 Fax: 703-224-0040

**ACA USE ONLY**

Booth No. Assigned: \_\_\_\_\_  
 Total Booth Fee: \_\_\_\_\_  
 Amount of Deposit: \_\_\_\_\_ Date Paid: \_\_\_\_\_  
 Amount of Balance: \_\_\_\_\_ Date Paid: \_\_\_\_\_  
 Authorized Signature (ACA) \_\_\_\_\_ Date \_\_\_\_\_

**2008 Exhibitor Prospectus**  
**138<sup>th</sup> Congress of Correction**  
**NEW ORLEANS, LOUISIANA • Aug. 8-13, 2008**

**Exhibit Booth Payment Information**

*Please indicate if payment is being made by credit card or check.  
**(50% Deposit due w/contract. Balance due thirty (30) days after invoice is received.)***

Please charge my credit card for \$ \_\_\_\_\_

Charge to:    VISA    MASTERCARD    AMERICAN EXPRESS    DISCOVER    Diner's Club

Cardholders Name  

Billing Address  

City  

State       Zip  

Credit Card Account #  

Security Code (on back of credit card)       Exp. Date     |   |

Signature Required: \_\_\_\_\_

I prefer to pay by check for \$ \_\_\_\_\_

Check Number           Check Dated     |   |

**Please return forms to ACA Show Management by faxing or mailing to:**

**CACR**  
**FAX:703-224-0040**  
**American Correctional Association**  
**206 N. Washington Street, Suite 200**  
**Alexandria, Virginia 22314**

*Booths can only be reserved with the 50% non-refundable deposit. Final payment must be received by ACA within 30 business days once booth confirmation has been received by vendor or deposit and space will be forfeited.*

# Decorating Services

## BOOTH FEES INCLUDE:

- Booth set-up, consisting of purple, gold and green flameproof draperies, forming 3-foot high side rails and an 8-foot backdrop
- One-line, 7-inch by 44-inch exhibitor identification sign and convention logo
- 24-hour Exhibit Hall security from move-in to move-out
- Exhibitor Service Kit
- General maintenance of the aisles and common Exhibit Hall areas to ensure a safe and attractive exposition
- Listing in ACA's 2008 ACA 138th Congress of Correction Program Book (includes company name and description, if contract is received by May 14, 2008)

## SHOW COLORS

Show colors are purple, gold and green. Aisles within the Exhibit Hall are carpeted in green. Show management requires that booths be completely carpeted at the exhibitor's expense. Exhibitors not furnishing their own carpeting must secure it through the George Fern Co. Exhibitors placing orders for carpeting and furniture in accordance with the deadline published on the order form in the Exhibitor Service Kit can save as much as 30 percent on the cost of these items.

## Show Service Contractor

George Fern is the official show service contractor. Exhibitors must use ACA's official show service contractor for drayage and rigging, furniture rentals, and other services as published in the Exhibitor Service Kit. Exhibitors are expected to have their booths in show condition each morning before the Exhibit Hall opens. Make any arrangements for cleaning services, available through ACA's official show service contractor, prior to the show. All of the above services are available at discount rates if contracted prior to the deadline indicated on the order form in the Exhibitor Service Kit. For other services, exhibitors desiring to use contractors other than those officially appointed by show management must advise show management and submit to ACA and ACA's official show service contractor the necessary certificates of insurance 30 days in advance of the initial opening of the show.

While the ACA has designated George Fern Co. as the official show service contractor, the ACA assumes no responsibility or liability for any of the services performed or products provided by such contractor.

## LABOR REQUIREMENTS

The service contractor is a union contractor, and requires union contracting in order to conform to rules and regulations. It is necessary that exhibitors use qualified personnel on the loading dock for material handling within the show. Louisiana is a right-to-work state which entitles exhibitors to set up and dismantle their own display/exhibit booths. Additionally, exhibitors are authorized to unload their own vehicles, making as many trips as necessary, and with the use of dollies if desired (no forklifts). More detailed information on labor requirements will appear in the Exhibitor Service Kit. Overtime for laborers applies to all hours before 8:00 a.m. and after 5:00 p.m. on weekdays, and all times during weekends and holidays.

## STORAGE OF PACKING BOXES OR CRATES

Storage crates, boxes or other extraneous materials are not to be stored in or behind the exhibit booths during the show. Arrangements must be made with the contractor for pick-up, storage, and return at published drayage rates.

## SHIPPING AND DRAYAGE

An Exhibitor Service Kit, providing information on equipment rental, drayage, electrical connections, plumbing, labor and other services, will be prepared by the show contractor and mailed to exhibitors by the ACA shortly after the ACA's receipt of the deposit and Booth Reservation Contract.

The shipping and drayage information contained in the service kit will instruct exhibitors to ship materials, prepaid in such a way that it arrives no sooner than 30 days in advance of the show's opening and no later than Thursday, Aug. 7, 2008 at 4:00 p.m. at the advance receiving warehouse. Please note that freight should be shipped with an accompanying bill of lading. When a bill of lading does not accompany a shipment, a premium charge will be levied for labor to locate that freight.

The name of the convention, along with the exhibiting company's name and assigned booth number, must appear on the shipping label. Shipments will not be accepted at the convention site before Saturday, Aug. 9, 2008. On Saturday, Aug. 9, 2008, but not before, exhibit materials can be shipped in care of George Fern Co., directly to Morial Convention Center.

Please read the shipping information and the drayage service order form included in the Exhibitor Service Kit, where you will also find details on the advance warehouse shipping address.

**Should there be any questions regarding decorating services or shipping after the Exhibitor Service Kit is reviewed, contact George Fern Co. at (502) 367-0254.**

# Display Rules and Regulations

- 1) A single exhibit booth may be occupied by only one company.
- 2) An exhibit booth must be occupied by the same company for the duration of the show.
- 3) All booths must be fully carpeted. Booths that are not fully carpeted will be carpeted by the show decorator at the expense of the exhibitor.
- 4) All displays, demonstrations, sales activities, etc., must be contained within the reserved booth space and may not impede traffic through the aisles. No solicitation or distribution of materials can take place within the Exhibit Hall aisles or in any other conference areas.
- 5) All booths are 10-feet deep by 10-feet wide, unless otherwise noted on the floor plan. Display dimensions may not exceed the 8-foot height of the backdrop or the 3-foot height of the side rails. A display may stand 8 feet in height only if it is flush with the booth's backdrop and extends no more than 4 feet from the back line of the booth at this height. The height of the booth must then drop down to the 3-foot height of the side rails. Other displays that do not conform to these specifications, including island and peninsula booths and multi-level booths are accepted and encouraged; however, **they must be approved by the ACA in writing a minimum of 90 days prior to the show due to infringement on the visibility of or interference with adjoining displays.** Displays violating this policy may be dismantled at the discretion of the ACA due to infringement on the visibility of or in displays. (See Diagram A.)
- 6) Exhibits that include the operation of radios, talking motion picture equipment, public address systems or any noise-making machines must be conducted or arranged so that the noise resulting from the demonstrations will not annoy or disturb adjacent exhibitors. Operators of noise-making exhibits must secure approval of operating methods before the exhibit opens. ACA Show Management shall have discretion to order removal or dismantling of exhibits not complying with this requirement.
- 7) Any display that exceeds normal display regulations (see Diagram A) must be approved in writing prior to the exhibit show. Permission must also be granted and arrangements must be made for any **oversized display** which may require early setup. Exhibitors who need to gain approval and make special arrangements must contact the ACA Exhibits Department at (800) 222-5646, ext. 0030, at least 60 days in advance of the show. Displays that do not conform to regulations as stated herein and have not been approved by ACA Show Management prior to the exhibit show will not be accepted. Upon approval, exhibitors will be directed to George Fern Co. to arrange for an early setup time, if applicable.
- 8) Because of insurance restrictions, all firearms must be transported in cases and exhibited/displayed inoperative. All firearms must be removed from the building each day after show hours. At no time shall firearms be loaded or contain live ammunition. Firing mechanisms on all firearms must be locked at all times. Firearms and ammunition will be inspected by an authorized safety inspector approved by the Convention Center during event move-in. Sale of firearms is prohibited in the Convention Center although exhibitors may take orders for future delivery.
- 9) Companies will not be allowed to place any materials in ACA's Registration Area.
- 10) Distribution of circulars or promotional material may be made only within the booth assigned to the exhibitor presenting such material. A firm or organization not assigned exhibit space will not be permitted to solicit business within the exhibit area or in any other conference areas.

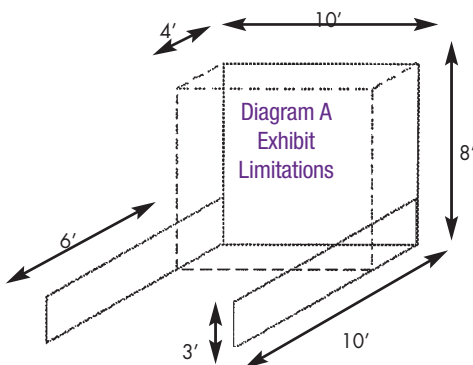

# Display Rules and Regulations (continued)

- 11) Combustible Materials Storage: Morial Convention Center requires that exhibitors' literature to be displayed or for distribution be limited to a one-day supply. Reserve supplies shall be kept in closed containers and stored outside the Convention Facility in a neat manner. All exhibit booths must be cleaned of combustible rubbish daily. The show decorator provides cleaning services. Storage of any materials will not be allowed behind the back curtain of the booth.
- 12) Subject to ACA's policy regarding attendance at and coverage of the Congress by representatives of the media and other publications, companies offering products or services to the corrections industry are eligible to exhibit at the Congress. ACA reserves the right to determine the eligibility of any company and, on the basis of that determination, to decline, to accept any exhibit booth contract or to cancel any contract already accepted from a company later determined to be ineligible to exhibit.
- 13) The ACA reserves the right to restrict exhibits that, because of noise, method of operation, materials, or for any other reason, become objectionable, and also reserves the right to prohibit any exhibit that, in the opinion of show management, may detract from the general character of the exhibit show as a whole. Should this occur, ACA shall not be liable to the exhibitor for refund of booth rental fees or for any other damages whatsoever.
- 14) Any and all outstanding debts with the ACA must be paid prior to any company, organization, or agency occupying an exhibit booth at any ACA show.
- 15) The ACA requires that any group, organization, corporation, company or other entity which advertises in ACA publications, or exhibits at ACA shows, respect the dignity of all individuals.
- \*16) Food and beverages may be served or consumed only if they constitute the product being exhibited. **A 3-ounce limitation is placed on the size of the cups used for beverage distribution, and a 3-ounce weight limitation is also placed on food items.** Any food or beverage served from an exhibitor's booth which does not represent the product being exhibited must be purchased through the official convention center catering contractor.
- 17) The use of helium balloons is prohibited.
- 18) The use of open flame, including fire acts, or the storage and handling of flammable liquids, chemicals or harmful caustic substances is prohibited, unless approved by the Fire Marshall. This approval must be coordinated via the ACA and received in writing no less than 60 days prior to the date of the show.
- 19) All exhibit and exhibit hall electrical installations, connections and disconnections must be obtained exclusively through the Building Electrical Contractor.
- 20) In order to preserve tax-exempt status with the Internal Revenue Service, ACA must insist that **no selling take place in the Exhibit Hall.** However orders may be taken by vendors.
- 21) The Convention Center and Exhibit Hall are smoke free.
- 22) Exhibitors which utilize or include in their exhibit materials or in their exhibit booths (a) material which is copyrighted by another, including without limitation live music or recorded music and/or videos which may or may not contain background music, or (b) materials incorporating matter subject to any other intellectual property right of another, must obtain proper licenses to use such materials, provided, however, that exhibitors need not obtain a license to utilize music the copyright to which is owned by BMI or ASCAP unless such music is utilized as background music, i.e. in a video and to be exhibited in the exhibit booth. Exhibitor agrees to defend and indemnify ACA, its officers, governors, employees, agents, subcontractors and the convention center authority against any and all claims, demands, suits or causes of action asserting infringement of copyright or any other intellectual property right in connection with the exhibitor's exhibit booth or exhibit materials.
- 23) Exhibit booths must be in compliance with the requirements of the Americans With Disabilities Act (ADA) for "places of public accommodation." Exhibitors hereby agree that they will defend, indemnify, and hold and save ACA, its officers, governors, employees and agents harmless from and against any and all claims, demands, actions, damages, loss, liabilities, expenses, and judgments recovered from or asserted against ACA on account of any actual or alleged failure of the exhibitor's exhibit booth to comply in any respect with the requirements of the ADA. Nothing in this agreement shall be deemed to be an admission by ACA or the exhibitor that either entity is a "public accommodation," or that the convention space or the exhibit booth leased hereunder is a "place of public accommodation," under the ADA.
- 24) Exhibitor represents and warrants that it is in full compliance with all federal, state, and local equal employment laws, rules, regulations and ordinances applicable to its operations.
- 25) Exhibitors accept full responsibility for their acts and conduct, as well as the acts and conduct of their invitees, within any part of the Exhibit Hall and conference area, and agree to defend and indemnify ACA against any and all claims, demands, actions, damages, losses, liabilities, expenses, and judgments recovered or asserted against ACA on account of any such acts or conduct.
- 26) During the exhibit setup and dismantling hours and in the evening after the close of exhibits, ACA will provide security service to cover entrances to the Exhibit Hall. During exhibit hours, exhibitors will be responsible for security in their booth(s). Small items of value should be removed from the area during non-show hours. **ACA shall not**, at any time, be responsible for the safety of the property of the exhibitors, its agents, employees or invitees, from theft or damage by fire, accident or due to any other cause. **Exhibitors are required to insure the contents of their exhibit booths.** The exhibitor assumes entire responsibility for losses, damages, and claims arising out of (a) damage to exhibitor's displays, equipment, and other property brought upon the premises of the Exhibit Hall and (b) injury to exhibitor employees, agents, or invitees within the Exhibit Hall. The exhibitor shall defend and indemnify ACA, its officers, governors, employees and agents against any and all claims, demands, actions, damages, losses, liabilities, expenses, and judgments recovered or asserted against ACA on account of any such damage or injury.
- 27) Exhibitors or their agents shall not injure or deface the walls of the building, the booths or the equipment of the booths, including via painting and staining. Exhibitors are not permitted to drive tacks, nails, or screws into the walls or woodwork. When such damage appears, the exhibitor is liable to the owner of the property so damaged. Use of stickers, decals, and adhesive materials is limited to the exhibitor's own display. Glitter is not permitted in the Exhibit Hall.
- 28) All materials used in displays must be flameproof and meet local fire regulations. All electrical wiring must conform to local codes. These regulations will be enforced.
- 29) New Orleans Fire Department requires that all fully enclosed exhibit spaces be equipped with smoke detectors and an annunciator located on the exterior of that space.
- 30) Any vehicle or combustion operated machine that is a part of an exhibit must contain a minimal amount of gasoline (less than one quarter tank) and must be equipped with locking gas caps. All battery cables must be disconnected and ends taped, gas caps locked, and the keys retained in either the Show Management or Building Management Office. No refueling is permitted in the Morial Convention Center. Exhibitors must protect floors under vehicles from any leakage, spillage, or other potential damage.
- 31) Running Fuel-Powered Motors or Machinery: All fuel-powered motors must have an exhaust system that will prevent any fumes from being emitted. Prior to show, ACA and Morial Convention Center approval is required. A Fire Watch may be required. This approval must be coordinated via the ACA and received in writing no less than 60 days prior to the date of the show.
- 32) Tents, Awnings, Canopies: The use or display of tents, awnings or canopies requires prior written approval of Morial Convention Center. This approval must be coordinated via the ACA Show Management and received in writing no less than 60 days prior to the date of the show and must include detailed plans showing size, height, location, anchoring details and certification of flame retardency for all materials. Morial Convention Center does not allow exhibitors to drill in the floor.
- 33) During Exhibit Hall setup or teardown, children under the age of 15 are not allowed in the Exhibit Hall.
- 34) No animals are permitted in Morial Convention Center without prior approval from ACA and the Morial Convention Center. In the event that approval is given, all sanitary needs for animals are the responsibility of the exhibitor. The exhibitor is liable to the owner of the property for damages.
- 35) As a courtesy to all exhibitors, hospitality suites shall not be open, and private parties shall not be permitted, during the scheduled hours of the trade show, ACA meetings or other ACA functions. Exhibitors scheduling private functions in conflict with official ACA events will jeopardize participation in future ACA shows.
- 36) In the event of cancellation of the 2008 ACA 138th Congress of Correction for any reason, ACA's liability to an exhibitor shall not exceed the amount of rental fees paid over and above the non-refundable deposit. The exhibitor's acceptance of these Rules and Regulations constitutes a release of ACA from any claims for damages in excess of said amount.
- 37) ACA shall not be liable for failure to perform its obligations hereunder due to strikes, riots, acts of God, or any other cause beyond its control.
- 38) All regulations as stated in this brochure are part of the legally binding booth reservation contract. In signing, the exhibitor agrees to abide by the regulations as stated here-in and on the Booth Reservation Contract itself.

In the event ACA determines an exhibitor is in violation of any of these Rules and Regulations, ACA Show Management will personally contact the senior exhibitor staff member present to advise that individual of the details of the violation. ACA will allow a reasonable amount of time for the exhibitor to correct the violation. If the infraction is not corrected within the time allowed, the exhibitor's booth may, at the sole discretion of ACA Show Management, be closed and/or dismantled without compensation to the exhibitor, and the exhibitor may forfeit the right to exhibit at future ACA events. All matters not covered by these Rules and Regulations shall be within the discretion of ACA Show Management. These Rules and Regulations may be amended at any time by ACA Show Management. Any such amendments shall be provided to, and shall be binding upon, all exhibitors.

**\* All Food and beverage items must be approved by ACA Show Management in cooperation with Convention Center Facility Catering.**